



Northwest Transmission Line Project

**Update to:
Alaska – British Columbia Intertie Project
Advisory Work Group Public Meeting**

October 29, 2007



BC Transmission
CORPORATION

Building Connections

Overview

- **About BCTC, BCH and transmission system**
- **Northwest Transmission Line (NTL)**
 - Overview
 - Route
 - Right-of-Way and structures
- **Key milestones and construction**



About BCTC

- Crown corporation formed in 2003
- Role: Plan, operate and maintain B.C.'s publicly owned electrical transmission system
- Reports to: Minister of Energy, Mines & Petroleum Resources; regulated by British Columbia Utilities Commission

About BC Hydro

- Crown corporation formed in 1962
- Role: Owns core transmission assets in the Province and is responsible for facilitating consultations with NTL First Nations on behalf of BCTC
- Reports to: Minister of Energy, Mines & Petroleum Resources; regulated by British Columbia Utilities Commission

The transmission system

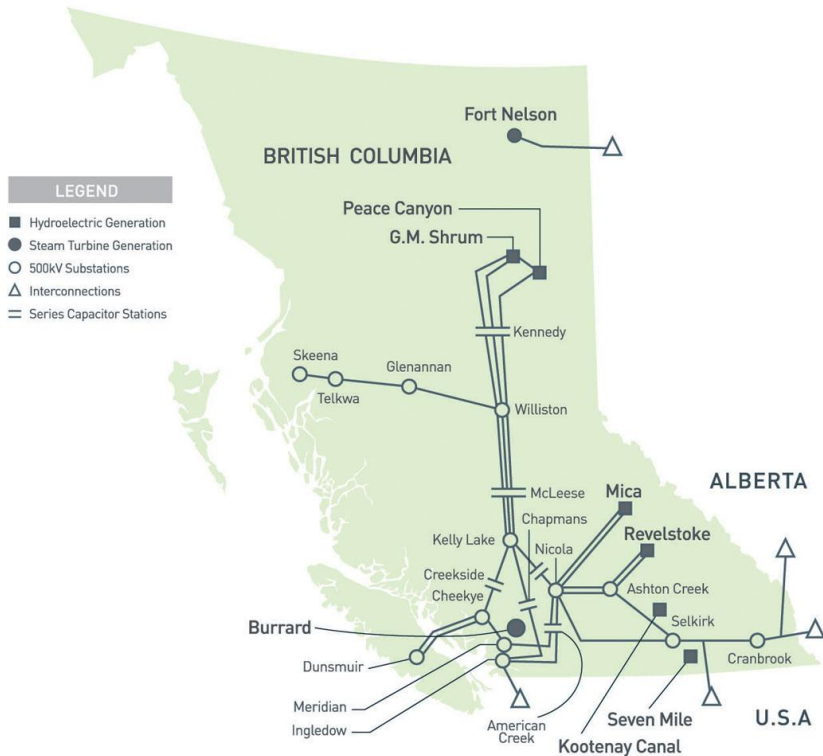

Interconnected grid:

- Approximately 18,200 km of transmission lines and cables
- 95,500 towers and poles
- 290 stations
- 5 control centres

The transmission grid in B.C. operates at voltages from 69 kilovolts (kV) to 500 kV and stretches over 75,000 hectares.

NTL - overview

- **A new 335 km, 287 kV transmission circuit**
- **Route from Skeena Substation (near Terrace) to a new substation near Bob Quinn Lake**
- **Would not replace the existing 138 kV circuit from Skeena Substation to Meziadin Junction**

Northwest Transmission Line (NTL)

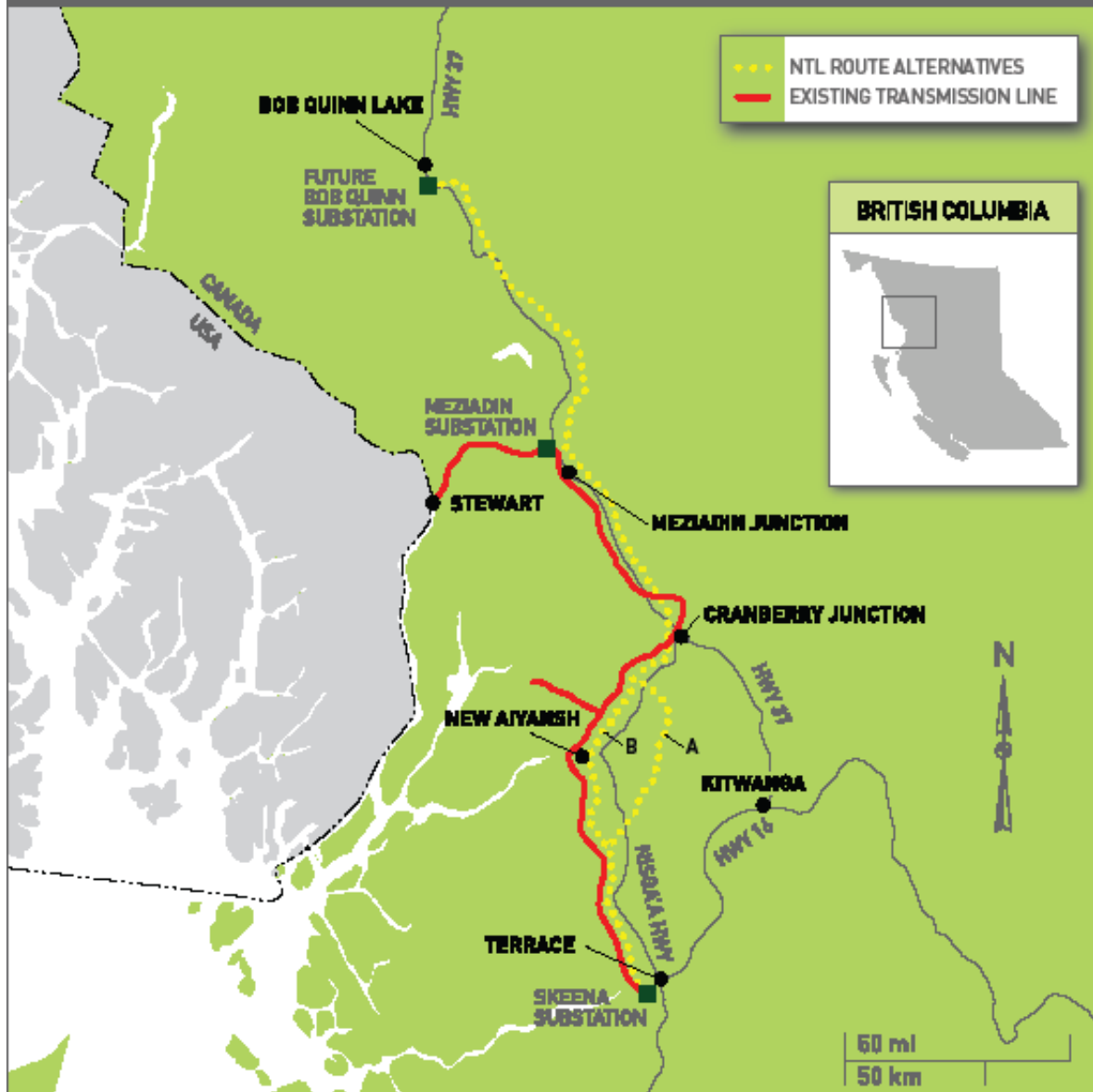

NTL routing

- General route location based on initial studies
- Alternative routes being studied in some locations
- New ROW required for much of route, even where route parallels existing 138 kV line

NTL route

- **New corridor/right-of-way will:**
 - Permit the straighter right-of-way required by a 287 kV circuit
 - Avoid difficult terrain
 - Minimize visual impacts
 - Lessen environmental impacts
- **Detailed route planning is underway**
- **Exact route and structure placement will take into account:**
 - Results of environmental studies and environmental assessment
 - Input from consultation with First Nations and stakeholders
 - Engineering design factors

Right-of-way

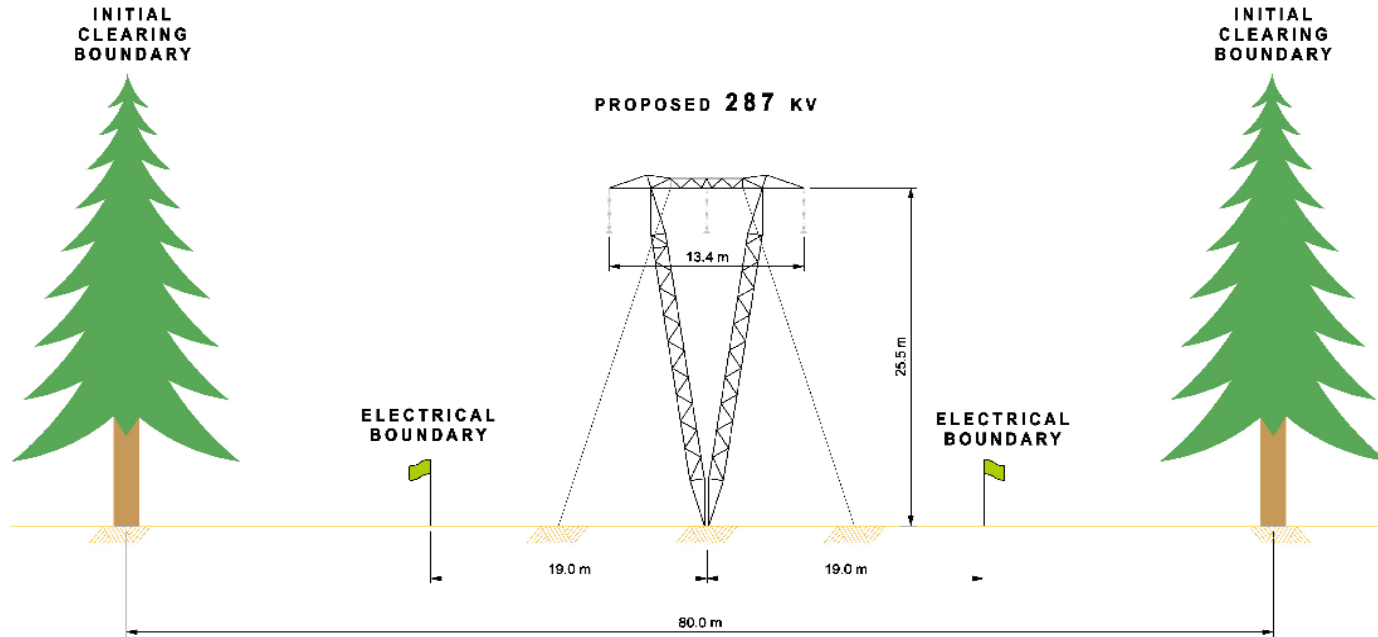

ROW width: 38 m

Extra one-time clearing on each side for security of line

TYPICAL NEW RIGHT - OF - WAY

Potential structure types

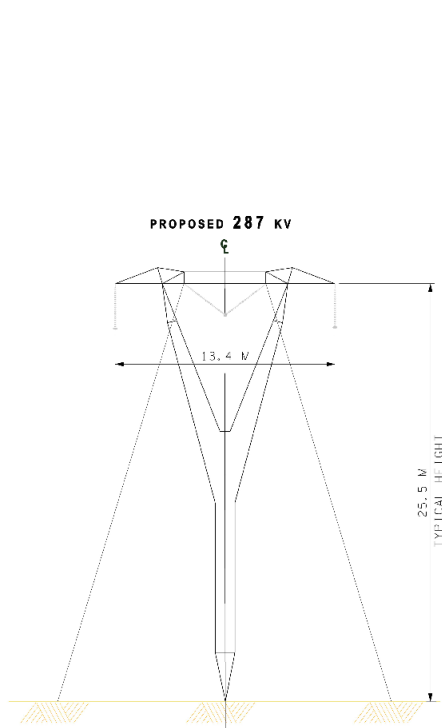

ALTERNATE LATTICE STEEL
OR STEEL POLE GUYED Y TANGENT
STRUCTURE w/ V-STRING

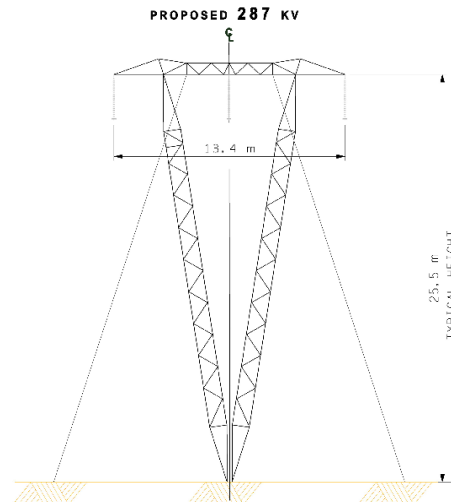

TYPICAL LATTICE STEEL
V-GUYED TANGENT
STRUCTURE

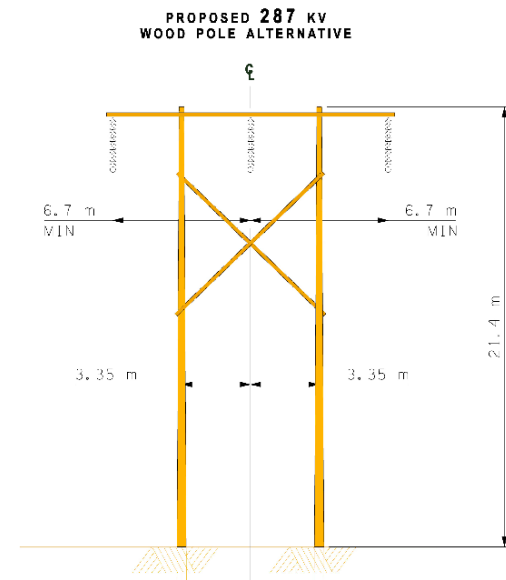

TYPICAL WOOD POLE
H-FRAME TANGENT
STRUCTURE

NTL construction plans

Two-phased

By Fall 2009:

- Build new substation near Bob Quinn Lake
- Build circuit between Meziadin Junction and Bob Quinn Lake, interconnecting to temporary switch yard near Meziadin Junction
- Energize at 138 kV

By Fall 2011:

- Construct circuit from Skeena Substation to Meziadin Substation
- Upgrade Skeena Substation
- Remove temporary facility near Meziadin Junction
- Energize circuit between Skeena Substation and Bob Quinn Substation to 287 kV

Key milestones

| Milestone | Dates (subject to change) |
|---|----------------------------|
| First Nations and public consultation | Ongoing |
| Project description accepted by BCEAO | June 2007 |
| File draft EA Terms of Reference (TOR) with BCEAO | October 2007 |
| Community meetings | November 2007 |
| Draft TOR public comment period | November 13 – Dec 13, 2007 |
| Finalize TOR; complete studies and effects assessments | January 2008 |
| File Environmental Assessment Certificate application with BCEAO | End of January 2008 |
| 45-day public comment period for EAC application/community meetings | March/April 2008 |
| Referral of EAC application to ministers | Summer/early fall 2008 |
| Ministers' decision re Environmental Assessment Certificate | Fall 2008 |
| First stage construction starts | Winter 2008/09 |
| First stage in-service | Oct 2009 |
| Second stage construction starts | Winter 2009/10 |
| Project completion/in-service | October 2011 |

For more information

www.bctc.com

(link to Northwest Transmission Line Project via home page)

Tim Jennings
BCTC Major Projects
604-699-7633
tim.jennings@bctc.com

Rohan Soulsby
BCTC, Director Business Development
604.699.7431
rohan.soulsby@bctc.com